

**ESD Diode**

**Features**

- Up to 2 lines protects
- Junction capacitance (Max value:10pF)
- Peak Pulse current (8/20μs) MAX: 3A
- IEC61000-4-2 (ESD) ±30kV (air), ±30kV (contact)
- Low leakage current
- Working voltages:24V
- P/N suffix V means AEC-Q101 qualified  
P/N suffix V means Halogen-free
- RoHS Compliant

**Mechanical Characteristics**

- Package: SOT-323
- Lead Finish:Matte Tin
- Case Material: "Green" Molding Compound.
- UL Flammability Classification Rating 94V-0
- Moisture Sensitivity: Level 1 per J-STD-020

**Applications**

- Cellular Handsets and Accessories
- Personal Digital Assistants
- Notebooks and Handhelds
- Portable Instrumentation
- Set Top Box
- Industrial Controls
- Server and Desktop PC

**Appearance&Symbol**

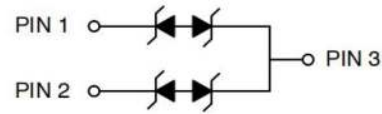
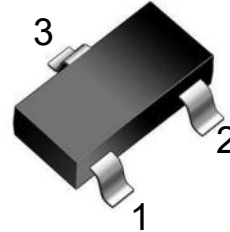

**Marking Information**

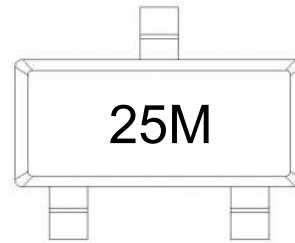

Marking Code 25M

**Absolute Maximum Ratings(T=25°Cunless otherwise noted)**

Parameters	Symbol	Value	Unit
Peak Pulse Power (tp=8/20μs waveform)	P <sub>PP</sub>	150	W
Peak Pulse Current (8/20μs)	I <sub>PP</sub>	3	A
ESD per IEC 61000-4-2 (Air) ESD per IEC 61000-4-2 (Contact)	V <sub>ESD</sub>	±30 ±30	KV
Operating Temperature Range	T <sub>J</sub>	-55to+150	°C
Storage Temperature Range	T <sub>stg</sub>	-55 to +150	°C

## Electrical Characteristics(T=25°Cunless otherwise noted)

Parameters	Symbol	Test Condition	Min	Typ	Max	Unit
Reverse Working Voltage	$V_{RWM}$		24			V
Reverse Breakdown Voltage	$V_{BR}$	$I_R = 1mA$	27	28.5	32	V
Reverse Leakage Current	$I_R$	$V_R = 24V$		15	100	nA
Clamping Voltage	$V_C$	$I_{PP} = 1A$ (8 x 20uS pulse)		33.4	36.6	V
Clamping Voltage	$V_C$	$I_{PP} = 3A$ (8 x 20uS pulse)		44	50	V
Junction Capacitance	$C_J$	$V_R = 0V, f = 1MHz$		7	10	pF
		$V_R = 5V, f = 1MHz$		4.5	6	
Diode Capacitance Matching	$\Delta C$	$V_R = 0V, f = 5MHz$		0.26	2	%

## RATING AND CHARACTERISTICS CURVES (TEPM24CMV)

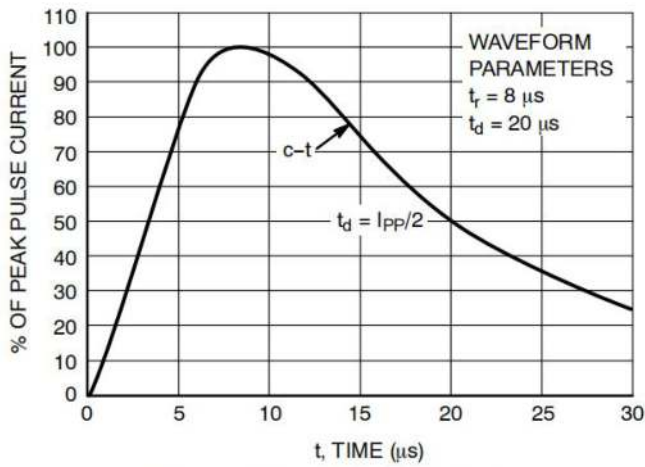

**Figure 1. Pulse Waveform, 8/20  $\mu\text{s}$**

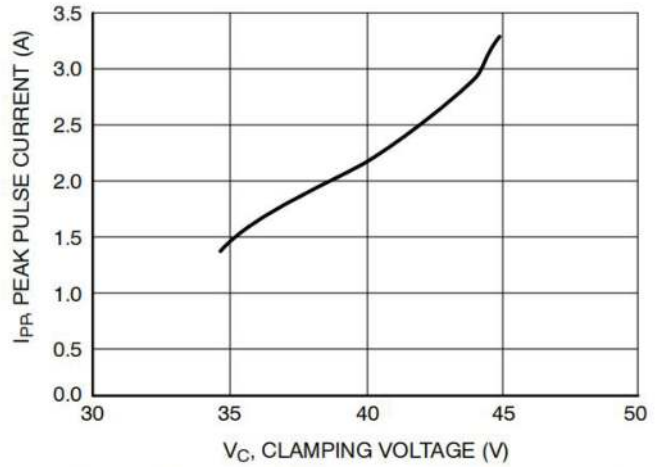

**Figure 2. Clamping Voltage vs Peak Pulse Current**

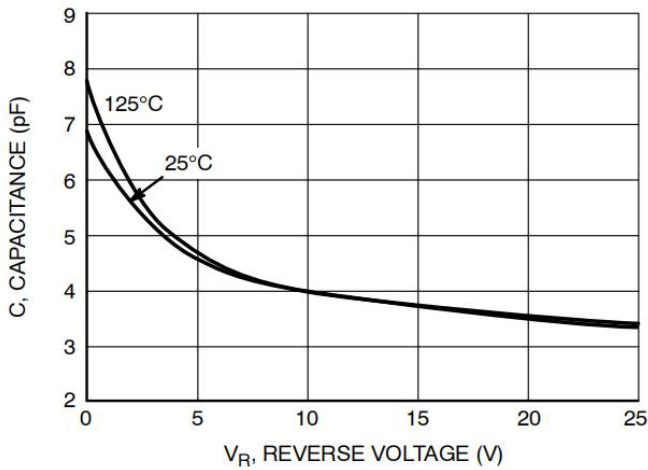

**Figure 3. Typical Junction Capacitance vs Reverse Voltage**

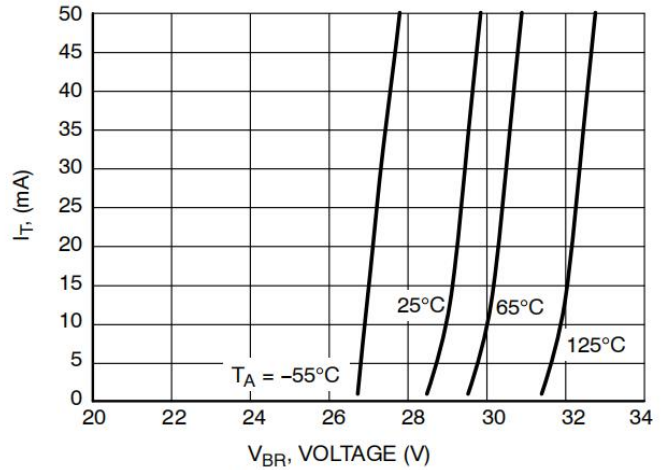

**Figure 4.  $V_{BR}$  versus  $I_T$  Characteristics**

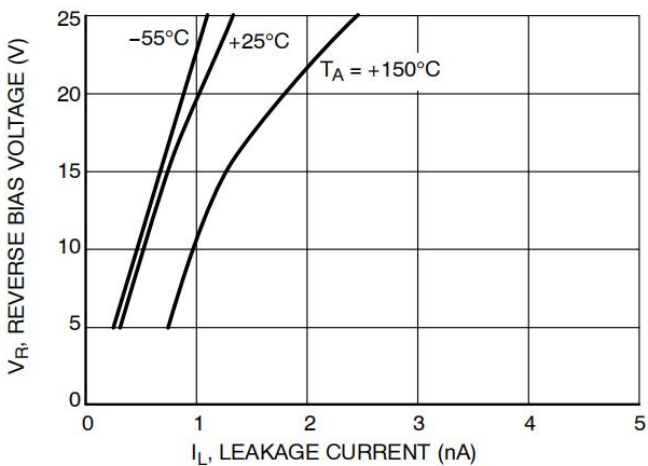

**Figure 5.  $I_R$  versus Temperature Characteristics**

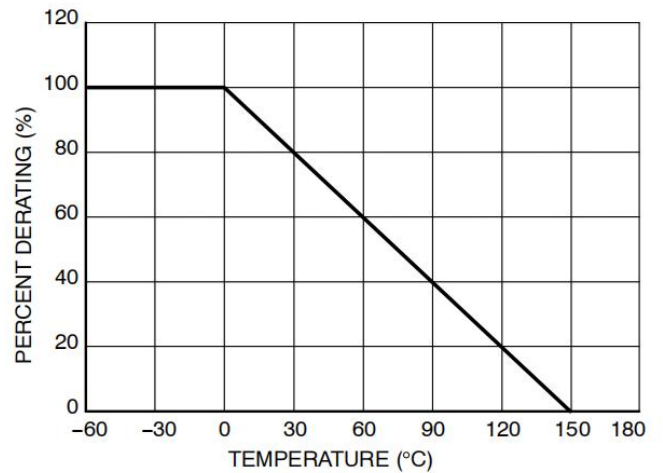

**Figure 6. Temperature Power Dissipation Derating**

## Soldering parameters

Reflow Condition		Pb-Free assembly (see as bellow)
Pre Heat	-Temperature Min ( $T_{s(min)}$ )	+150°C
	-Temperature Max( $T_{s(max)}$ )	+200°C
	-Time (Min to Max) ( $t_s$ )	60-180 secs.
Average ramp up rate (Liquid us Temp ( $T_L$ ) to peak)		3°C/sec. Max
$T_{s(max)}$ to $T_L$ - Ramp-up Rate		3°C/sec. Max
Reflow	-Temperature( $T_L$ ) (Liquid us)	+217°C
	-Temperature( $t_L$ )	60-150 secs.
Peak Temp ( $T_p$ )		+260(+0/-5)°C
Time within 5°C of actual Peak Temp ( $t_p$ )		30 secs. Max
Ramp-down Rate		6°C/sec. Max
Time 25°C to Peak Temp ( $T_p$ )		8 min. Max
Do not exceed		+260°C

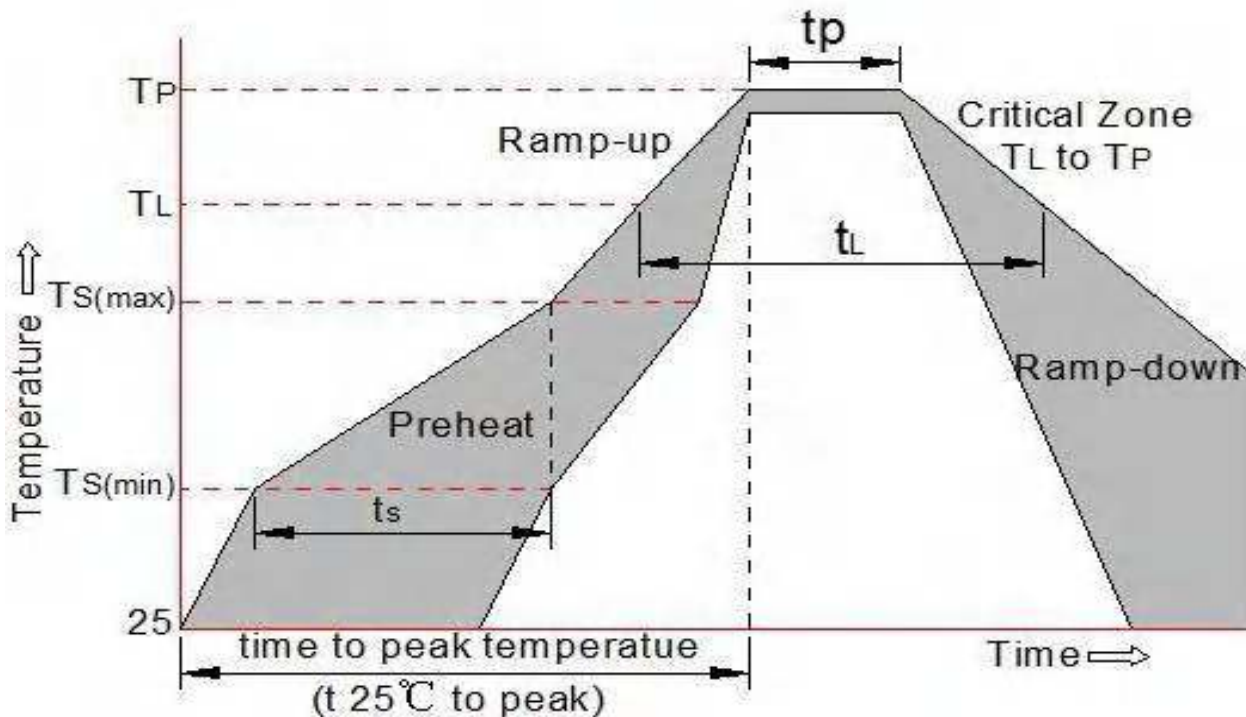

### Package mechanical data

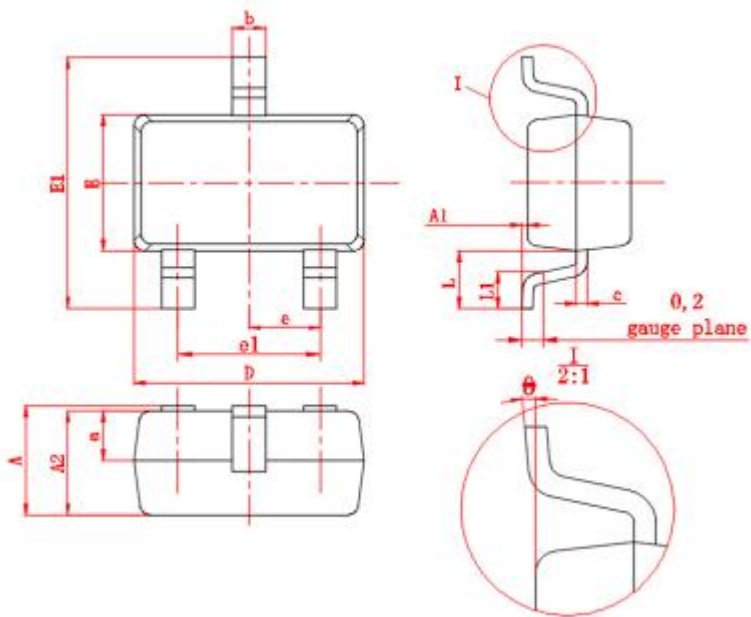

Symbol	Millimeters	
	Min	Max
A	0.9	1.1
A1	0	0.1
A2	0.9	1.0
a	(0.45)	
D	2.0	2.2
E	1.15	1.35
E1	2.15	2.45
e	(0.65)	
e1	1.2	1.4
b	0.25	0.35
c	0.08	0.15
L	(0.525)	
L1	0.26	0.46
θ	0°	8°

### Suggested Land Pattern

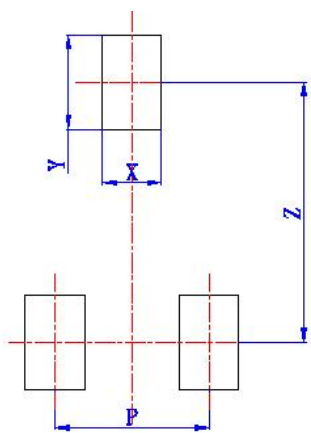

Symbol	Dimension in Millimeters
	Typ
X	(0.5)
Y	(0.8)
Z	(1.8)
P	(1.3)

## Tape & reel specification

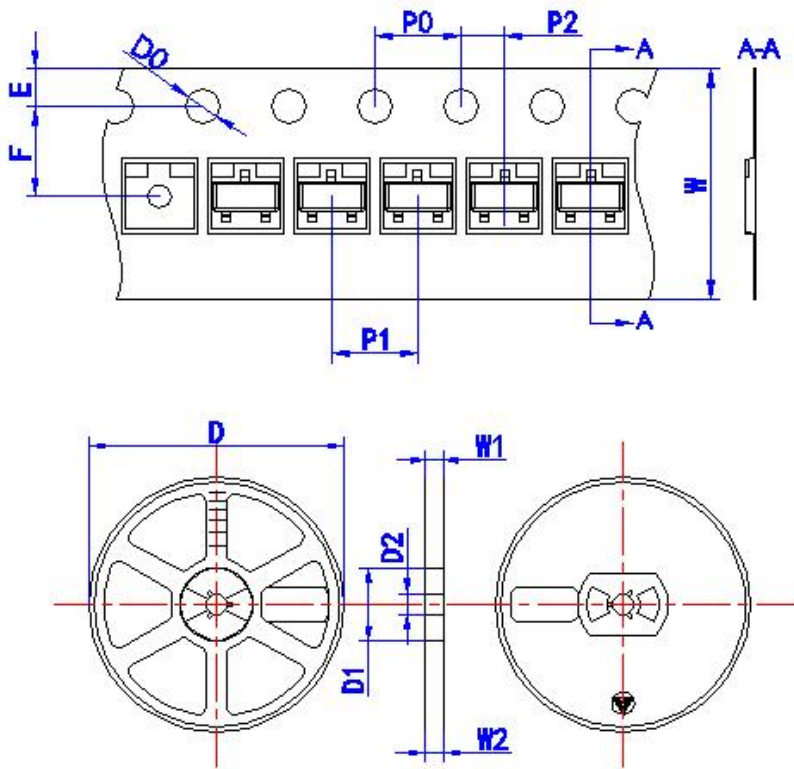

Symbol	Dimension in Millimeters
<b>Tape</b>	
D0	1.50+0.10/-0.00
E	1.75±0.10
F	3.50±0.10
P0	4.00±0.10
P1	4.00±0.10
P2	2.00±0.10
W	8.00+0.3/-0.1
<b>Reel</b>	
D	178.0±2.00
D1	54.40±1.00
D2	13.00±1.00
W1	9.50±1.00
W2	12.30±1.00

### REEL PACK

PACKAGE	PACKING CODE	REEL ( EA )	COMPONENT SPACE(mm)	TAPE SPACE (mm)	REEL DIA (mm)	CARTON SIZE (mm)	EA PER CARTON	GROSS WEIGHT(Kg)
SOT-323	-T	3,000	---	---	178	390*205*310	120,000	5.29

## DISCLAIMER NOTICE

Rectron Inc reserves the right to make changes without notice to any product specification herein, to make corrections, modifications, enhancements or other changes. Rectron Inc or anyone on its behalf assumes no responsibility or liability for any errors or inaccuracies. Data sheet specifications and its information contained are intended to provide a product description only. "Typical" parameters which may be included on RECTRON data sheets and/ or specifications can and do vary in different applications and actual performance may vary over time. Rectron Inc does not assume any liability arising out of the application or use of any product or circuit.

Rectron products are not designed, intended or authorized for use in medical, life-saving implant or other applications intended for life-sustaining or other related applications where a failure or malfunction of component or circuitry may directly or indirectly cause injury or threaten a life without expressed written approval of Rectron Inc. Customers using or selling Rectron components for use in such applications do so at their own risk and shall agree to fully indemnify Rectron Inc and its subsidiaries harmless against all claims, damages and expenditures.