

Surface Mount Schottky Rectifier

Features

- Low profile package
- Ideal for automated placement
- Guardring for overvoltage protection
- Low power losses, high efficiency
- High forward surge capability
- Meets MSL level 1, per J-STD-020, LF maximum peak of 260 °C

DO-214AC (SMA)

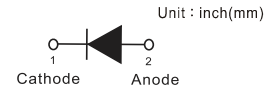
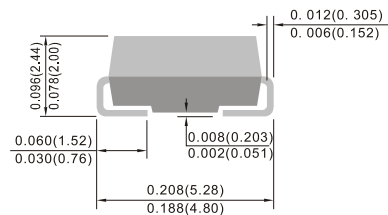
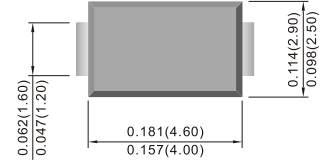

Typical Applications

For use in low voltage high frequency inverters, freewheeling, DC/DC converters, and polarity protection applications.

Mechanical Data

- **Package:** DO-214AC (SMA)
Molding compound meets UL 94 V-0 flammability rating, RoHS-compliant, halogen-free
- **Terminals:** Tin plated leads, solderable per J-STD-002 and JESD22-B102
- **Polarity:** Cathode line denotes the cathode end

Maximum Ratings (T_a=25°C Unless otherwise specified)

PARAMETER	SYMBOL	UNIT	SS								
			12A	13A	14A	15A	16A	18A	110A	115A	120A
Repetitive peak reverse voltage	V _{RRM}	V	20	30	40	50	60	80	100	150	200
Average rectified output current @60Hz sine wave, resistance load, TL (FIG.1)	I _O	A	1.0								
Surge(non-repetitive)forward current @60Hz half-sine wave, 1 cycle, T _a =25°C	I _{FSM}	A	30								
Storage temperature	T _{stg}	°C	-55 ~+150								
Junction temperature	T _j	°C	-55 ~+150						-55 ~+175		

Electrical Characteristics (T_a=25°C Unless otherwise specified)

PARAMETER	SYMBOL	UNIT	TEST CONDITIONS	SS							
				12A	13A	14A	15A	16A	18A	110A	115A
Maximum instantaneous forward voltage drop per diode	V _F	V	I _{FM} =1.0A	0.55			0.70		0.85		0.95
Maximum DC reverse current at rated DC blocking voltage per diode@ V _{RM} =V _{RRM}	I _{RRM}	mA	T _a =25°C	0.50				0.10			
			T _a =100°C	10				5.0			

Thermal Characteristics (T_a=25°C Unless otherwise specified)

PARAMETER	SYMBOL	UNIT	SS								
			12A	13A	14A	15A	16A	18A	110A	115A	120A
Thermal resistance	R _{θJ-A}	°C/W	65 ¹⁾								
	R _{θJ-L}		20 ¹⁾								

Note

(1) Thermal resistance from junction to ambient and from junction to lead mounted on P.C.B. with 0.2" x 0.2" (5.0 mm x 5.0 mm) copper pad areas

RATING AND CHARACTERISTICS CURVES (SS12A THRU SS120A)

FIG1: I_o -TL Curve

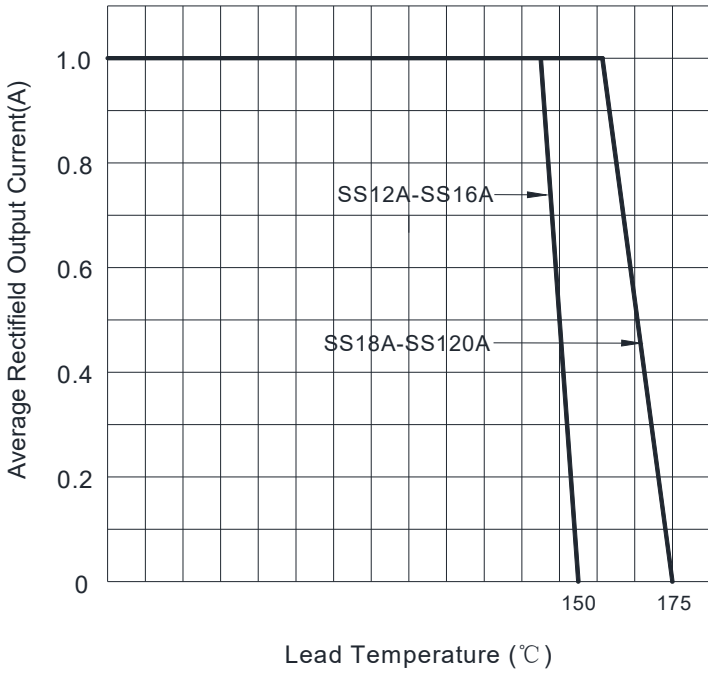

FIG2: Surge Forward Current Capability

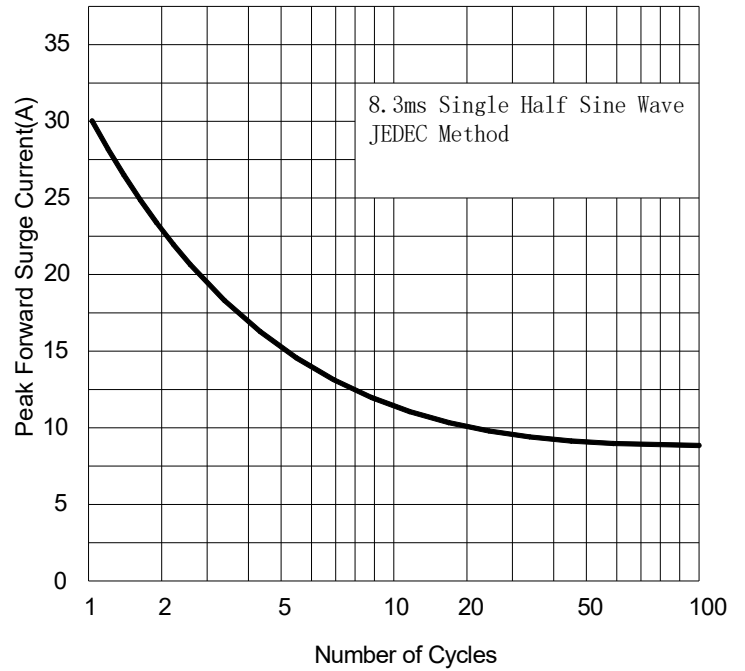

FIG3: TYPICAL FORWARD CHARACTERISTICS

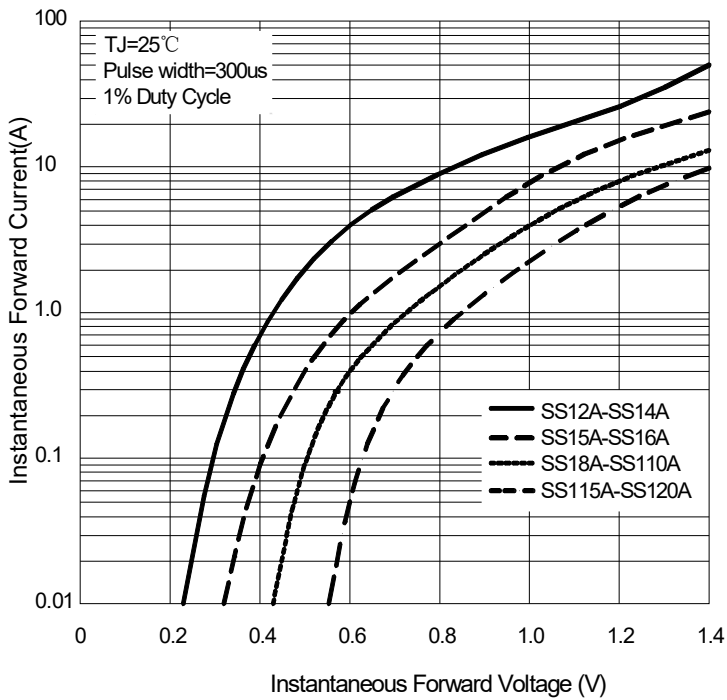
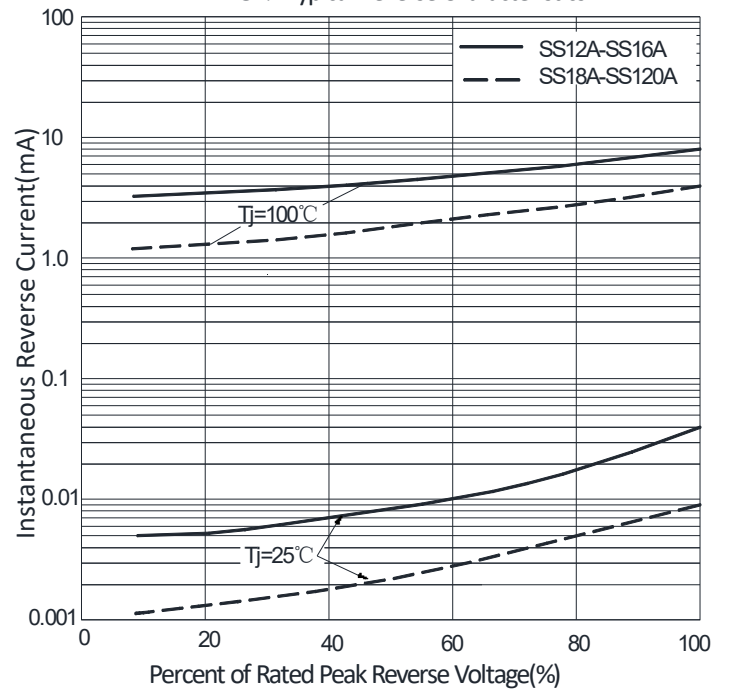
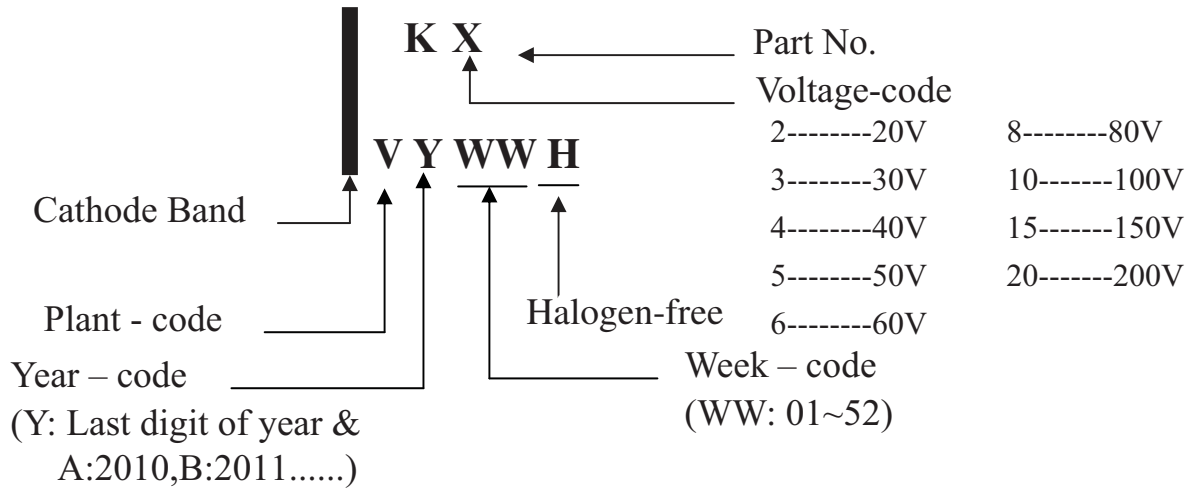

FIG4: Typical Reverse Characteristics



Marking Description



PACKAGING OF DIODE AND BRIDGE RECTIFIERS

REEL PACK

PACKAGE	PACKING CODE	EA PER REEL	EA PER INNER BOX	COMPONENT SPACE (mm)	TAPE SPACE (mm)	REEL DIA (mm)	CARTON SIZE (mm)	EA PER CARTON	GROSS WEIGHT(Kg)
SMA	-W	7,500	15,000	---	---	330	360*355*360	120,000	15.2

PACKAGE	PACKING CODE	EA PER REEL	EA PER INNER BOX	COMPONENT SPACE (mm)	TAPE SPACE (mm)	REEL DIA (mm)	CARTON SIZE (mm)	EA PER CARTON	GROSS WEIGHT(Kg)
SMA	-T	2,000	8,000	---	---	178	390*205*310	64,000	7.8

DISCLAIMER NOTICE

Rectron Inc reserves the right to make changes without notice to any product specification herein, to make corrections, modifications, enhancements or other changes. Rectron Inc or anyone on its behalf assumes no responsibility or liability for any errors or inaccuracies. Data sheet specifications and its information contained are intended to provide a product description only. "Typical" parameters which may be included on RECTRON data sheets and/ or specifications can and do vary in different applications and actual performance may vary over time. Rectron Inc does not assume any liability arising out of the application or use of any product or circuit.

Rectron products are not designed, intended or authorized for use in medical, life-saving implant or other applications intended for life-sustaining or other related applications where a failure or malfunction of component or circuitry may directly or indirectly cause injury or threaten a life without expressed written approval of Rectron Inc. Customers using or selling Rectron components for use in such applications do so at their own risk and shall agree to fully indemnify Rectron Inc and its subsidiaries harmless against all claims, damages and expenditures.