

Surface Mount General Purpose Silicon Rectifiers
Reverse Voltage - 50 to 1000 V Forward Current - 1 A

FEATURES

- For surface mounted applications
- Low profile package
- Glass Passivated Chip Junction
- Easy to pick and place
- Lead free in comply with EU RoHS 2011/65/EU directives

MECHANICAL DATA

- Case: SMAHE-C
- Terminals: Solderable per MIL-STD-750, Method 2026
- Approx. Weight: 30mg / 0.0010oz

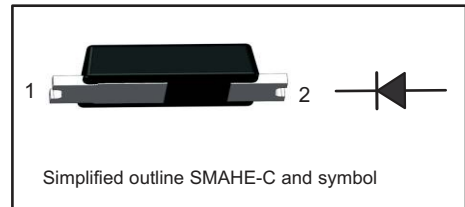

PIN	DESCRIPTION
1	Cathode
2	Anode

Maximum Ratings and Electrical characteristics
Ratings at 25 °C ambient temperature unless otherwise specified.
Single phase half-wave 60 Hz, resistive or inductive load, for capacitive

Parameter	Symbols	S1AAHE	S1BAHE	S1DAHE	S1GAHE	S1JAHE	S1KAHE	S1MAHE	Units
Maximum Repetitive Peak Reverse Voltage	V_{RRM}	50	100	200	400	600	800	1000	V
Maximum RMS voltage	V_{RMS}	35	70	140	280	420	560	700	V
Maximum DC Blocking Voltage	V_{DC}	50	100	200	400	600	800	1000	V
Maximum Average Forward Rectified Current@ Fig.1	$I_{F(AV)}$	1							A
Peak Forward Surge Current,8.3ms Single Half Sine-wave Superimposed on Rated Load (JEDEC method)	I_{FSM}	30							A
Peak Forward Surge Current,1ms Single Half Sine-wave Superimposed on Rated Load (JEDEC method)	I_{FSM}	60							A
I^2t Rating for fusing(3ms≤t≤8.3ms)	I^2t	3.7							A ² S
Maximum Instantaneous Forward Voltage at 1 A	V_F	1.1							V
Maximum DC Reverse Current at Rated DC Blocking Voltage $T_j = 25\text{ °C}$ $T_j = 125\text{ °C}$	I_R	5 100							μA
Typical Junction Capacitance ⁽¹⁾	C_j	7							pF
Typical Thermal Resistance ⁽²⁾	$R_{\theta JA}$ $R_{\theta JC}$ $R_{\theta JL}$	95 20 25							°C/W
Operating and Storage Temperature Range	T_j, T_{stg}	-55 ~ +150							°C

(1) Measured at 1 MHz and applied reverse voltage of 4 V D.C

(2) P.C.B. mounted with 0.2"X 0.2" (5 X 5 mm) copper pad areas.

RATING AND CHARACTERISTICS CURVES (S1AAHE THRU S1MAHE)

Fig.1 Forward Current Derating Curve

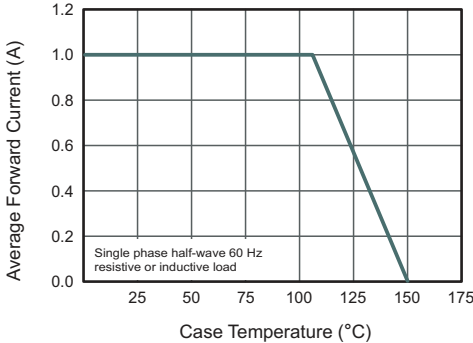

Fig.2 Typical Instaneous Reverse Characteristics

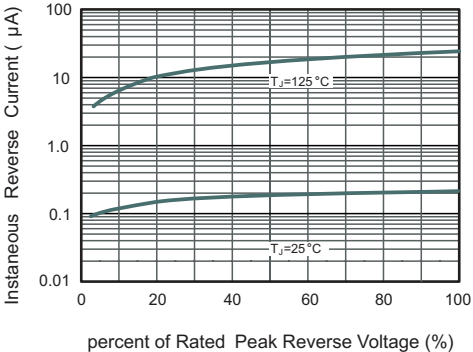

Fig.3 Typical Forward Characteristic

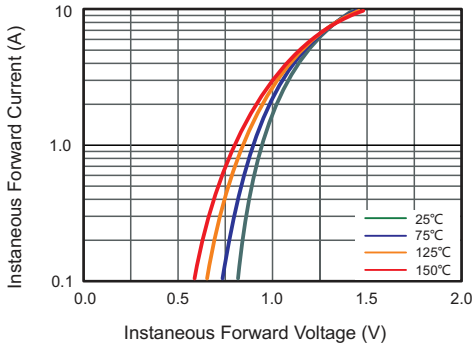

Fig.4 Typical Junction Capacitance

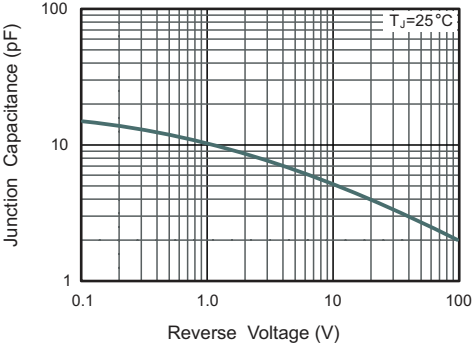
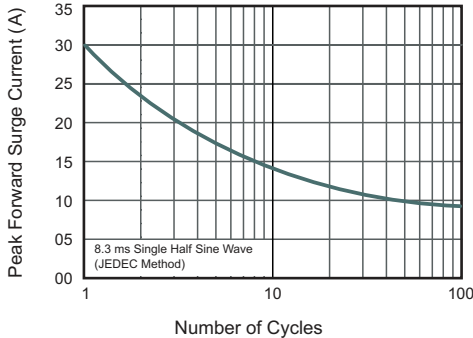

Fig.5 Maximum Non-Repetitive Peak Forward Surge Current



PACKAGE OUTLINE

Plastic surface mounted package; 2 leads

SMAHE-C

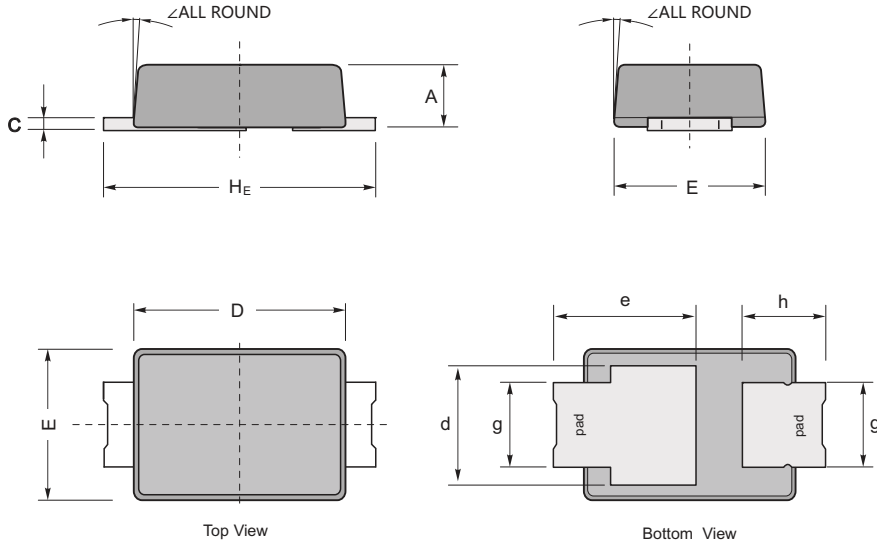

UNIT		A	C	D	E	H_E	d	e	g	h	\angle
mm	max	1.20	0.35	4.10	2.70	5.20	1.90	3.05	1.50	1.2	12°
	min	0.90	0.20	3.70	2.30	4.80	1.70	2.85	1.30	0.8	
mil	max	47	13.8	161	106	205	75	120	59	47	
	min	35	7.9	145	90	189	67	112	51	32	

The recommended mounting pad size

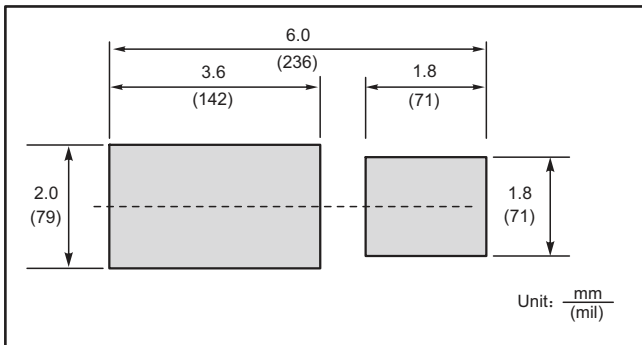

Marking Description

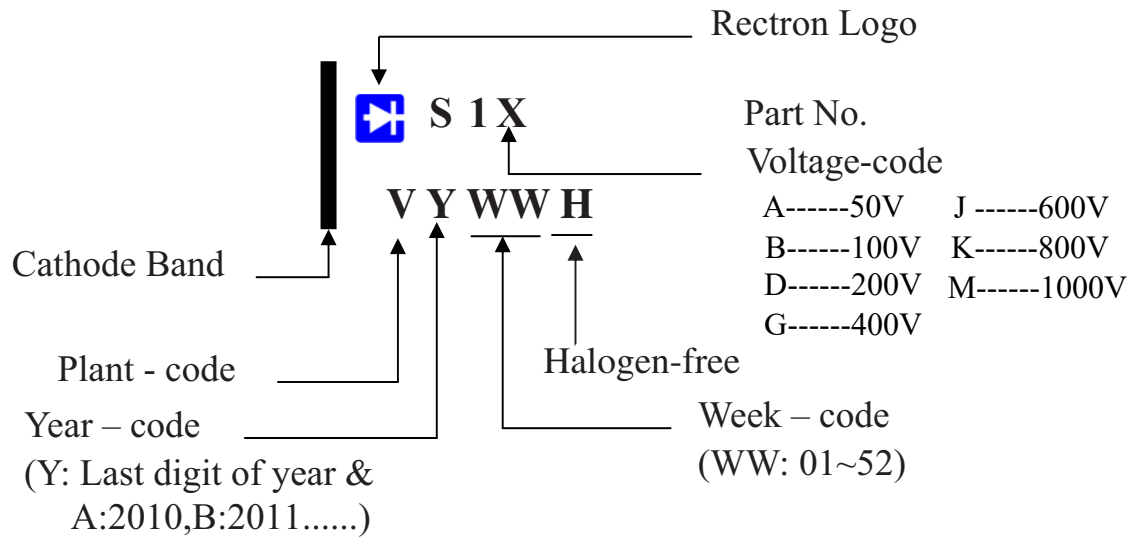

PACKAGING OF DIODE AND BRIDGE RECTIFIERS

REEL PACK

PACKAGE	PACKING CODE	PER REEL (EA)	REEL DIA (mm)	INNER BOX (EA)	BOX SIZE (mm)	CARTON SIZE (mm)	PER CARTON (EA)
SMAHE	-W	10,000	330	20,000	340*340*40	355*355*235	100,000

Tape data (Units: mm)

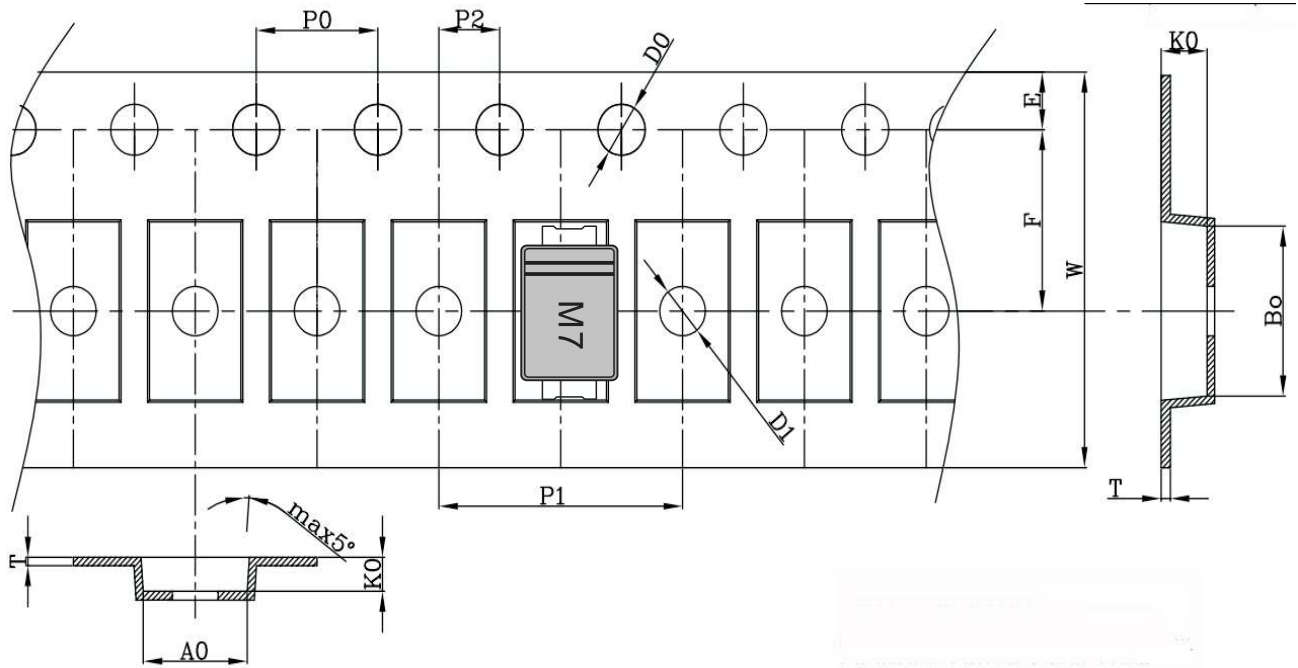

Symbol	A0	B0	K0	P0	P1	P2
Spec	2.85±0.1	5.25±0.1	1.25±0.1	4.0±0.1	4.0±0.1	2.0±0.1
Symbol	T	E	F	D0	D1	W
Spec	0.22±0.02	1.75±0.1	5.5±0.05	1.55±0.05	1.55±0.05	12 ^{+0.3} _{-0.1}

Reel data (Units: mm)

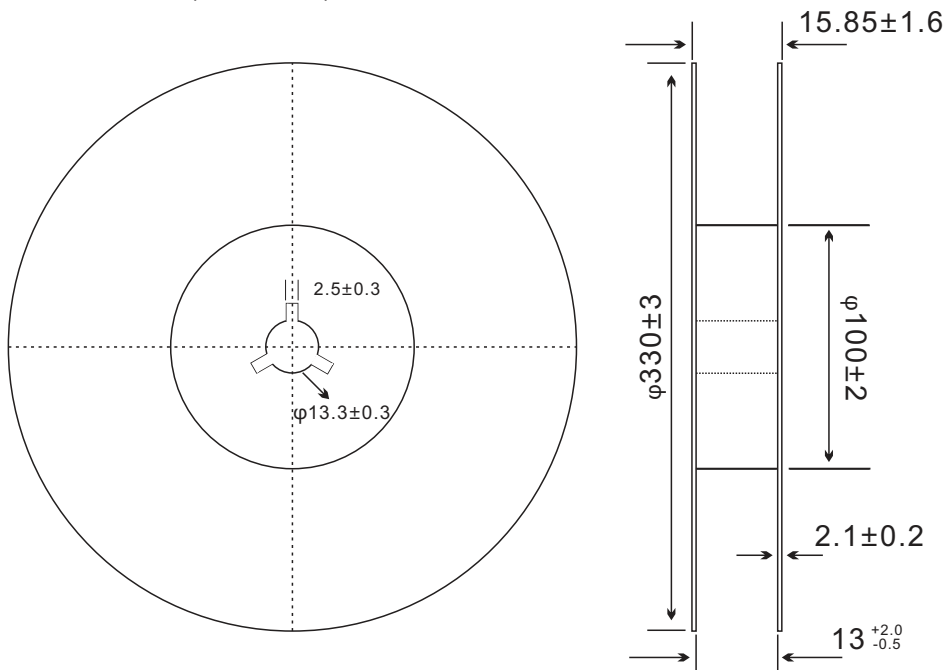

DISCLAIMER NOTICE

Rectron Inc reserves the right to make changes without notice to any product specification herein, to make corrections, modifications, enhancements or other changes. Rectron Inc or anyone on its behalf assumes no responsibility or liability for any errors or inaccuracies. Data sheet specifications and its information contained are intended to provide a product description only. "Typical" parameters which may be included on RECTRON data sheets and/ or specifications can and do vary in different applications and actual performance may vary over time. Rectron Inc does not assume any liability arising out of the application or use of any product or circuit.

Rectron products are not designed, intended or authorized for use in medical, life-saving implant or other applications intended for life-sustaining or other related applications where a failure or malfunction of component or circuitry may directly or indirectly cause injury or threaten a life without expressed written approval of Rectron Inc. Customers using or selling Rectron components for use in such applications do so at their own risk and shall agree to fully indemnify Rectron Inc and its subsidiaries harmless against all claims, damages and expenditures.