

150V NPN MEDIUM POWER TRANSISTOR

Features

1. BVCEO > 150V
2. IC = 1A High Continuous Current
3. Low Saturation Voltage VCE(sat)<300mV @0.5A
4. Marking: N95

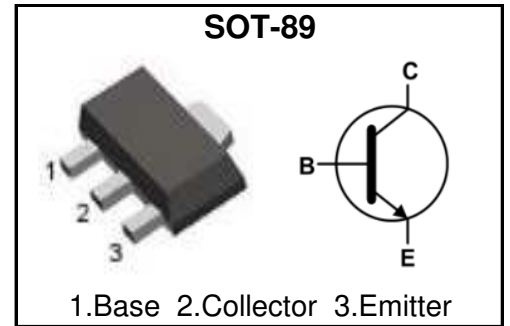

Maximum ratings(Ta=25°C unless otherwise noted)

Parameter	Symbol	Value	Unit
Collector Base Voltage	V _{CBO}	170	V
Collector Emitter Voltage	V _{CEO}	150	V
Emitter Base Voltage	V _{EBO}	7	V
Collector Current	I _C	1	A
Collector Power Dissipation	P _C	1	W
Junction Temperature	T _J	150	°C
Storage Temperature	T _{stg}	-65~150	°C

Electrical Characteristics (Ta=25°C unless otherwise noted)

Parameter	Symbol	Test Condition	Min	Max	Unit
Collector-Base Breakdown Voltage	V _{CBO}	I _C =100uA I _E =0	170		V
Collector-Emitter Breakdown Voltage	V _{CEO}	I _C =1mA I _B =0	150		V
Emitter-Base Breakdown Voltage	V _{EBO}	I _E =100uA I _C =0	7		V
Collector Cutoff Current	I _{CBO}	V _{CB} =150V I _E =0		100	nA
Emitter Cutoff Current	I _{EBO}	V _{EB} =5.6V I _C =0		100	nA
DC Current Gain	H _{FE}	V _{CE} =10V I _C =1mA	100		
		V _{CE} =10V I _C =250mA	100	300	
		V _{CE} =10V I _C =500mA	50		
		V _{CE} =10V I _C =1A	10		
Collector-Emitter Saturation Voltage	V _{CE(sat)}	I _C =250mA I _B =25mA		0.2	V
	V _{CE(sat)}	I _C =500mA I _B =50mA		0.3	
Base-Emitter Saturation Voltage	V _{BE(sat)}	I _C =500mA I _B =50mA		1	V
Base-Emitter Turn-On Voltage	V _{BE(on)}	V _{CE} =10V I _C =500mA		1	V
Transition frequency	f _T	V _{CE} =10V I _C =50mA	100		MHz
Collector output capacitance	C _{ob}	V _{CB} =10V, f=1MHz		10	pF

RATING AND CHARACTERISTICS CURVES (RTFCX495T89)

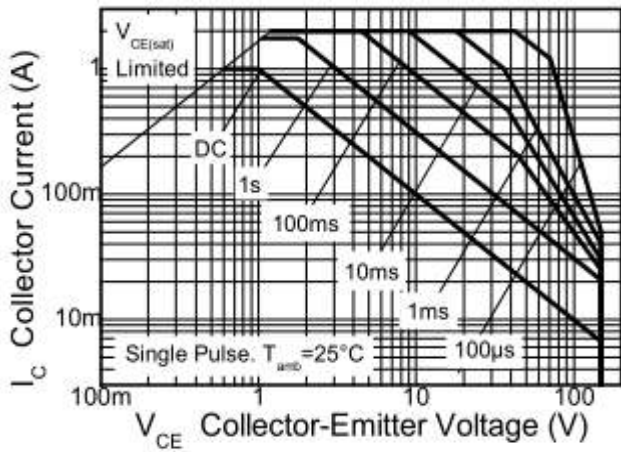

Safe Operating Area

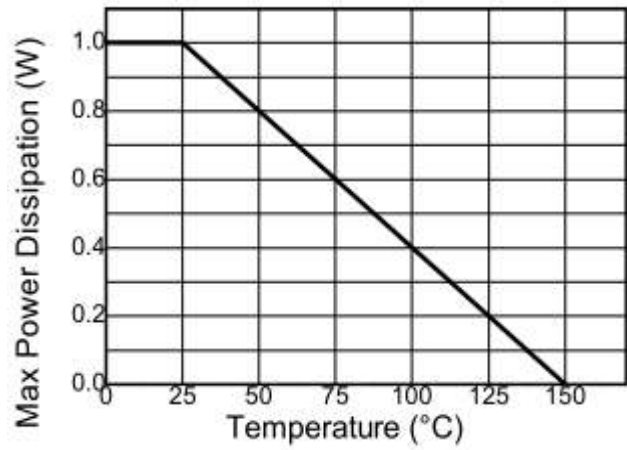

Derating Curve

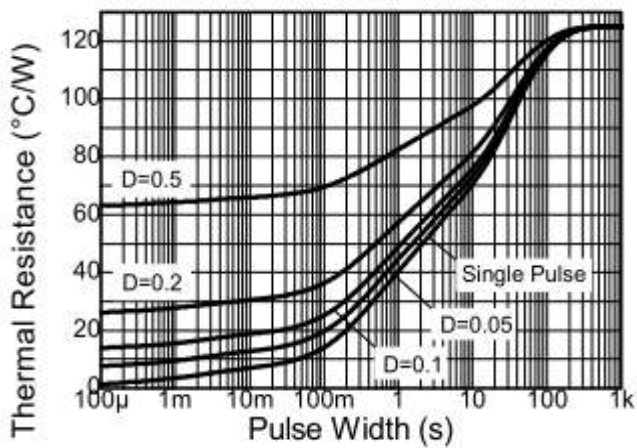

Transient Thermal Impedance

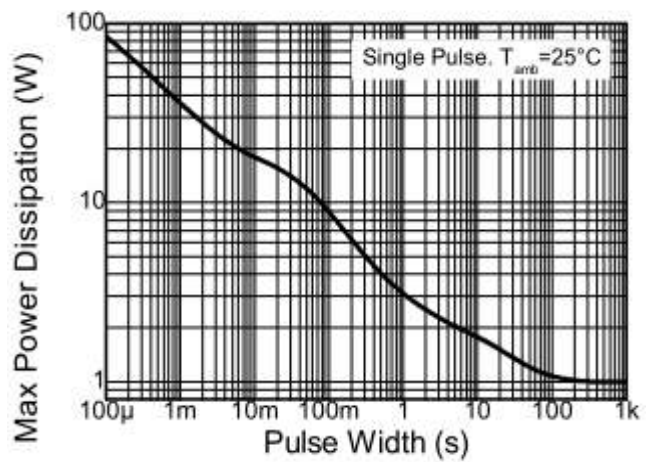

Pulse Power Dissipation

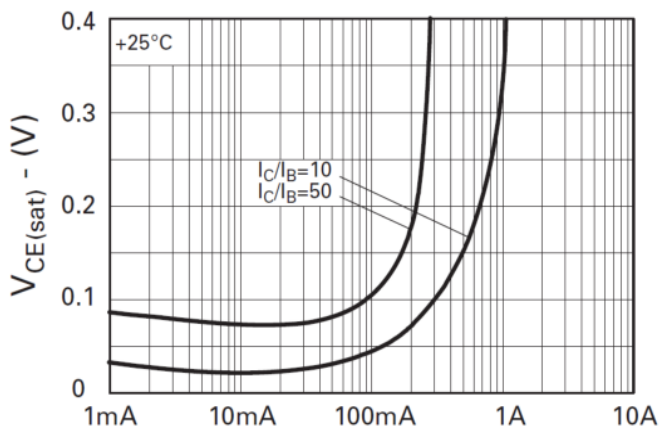

I_C - Collector current
 $V_{CS(sat)}$ vs. I_C

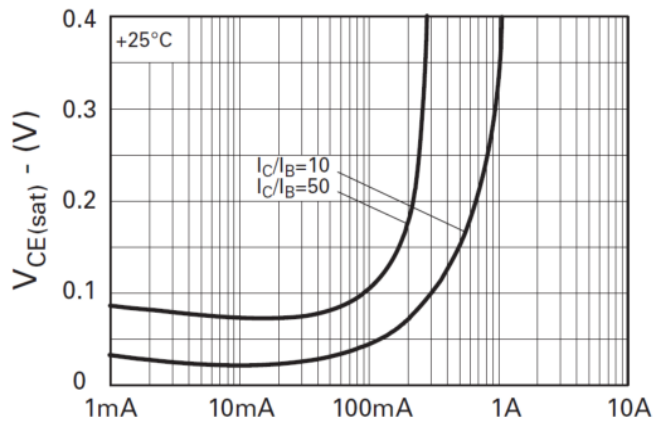

I_C - Collector current
 $V_{CS(sat)}$ vs. I_C

RATING AND CHARACTERISTICS CURVES (RTFCX495T89)

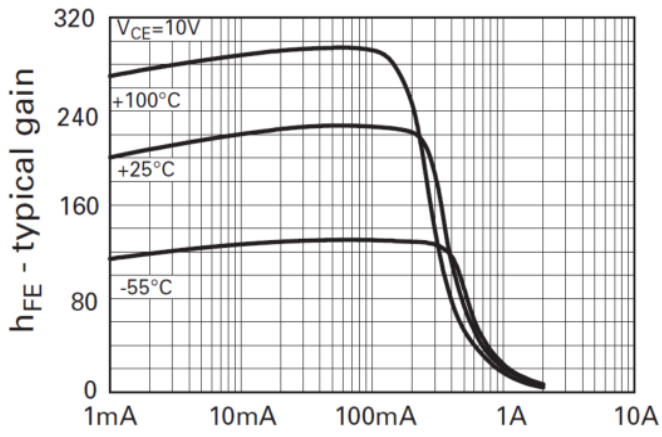

I_C - Collector current
 h_{FE} vs. I_C

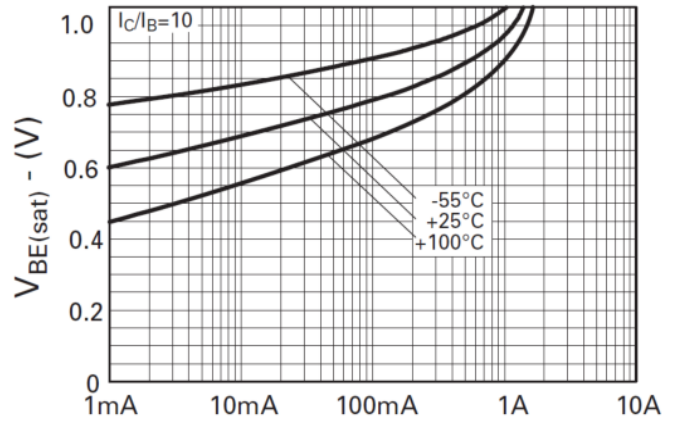

I_C - Collector current
 $V_{BE(sat)}$ vs. I_C

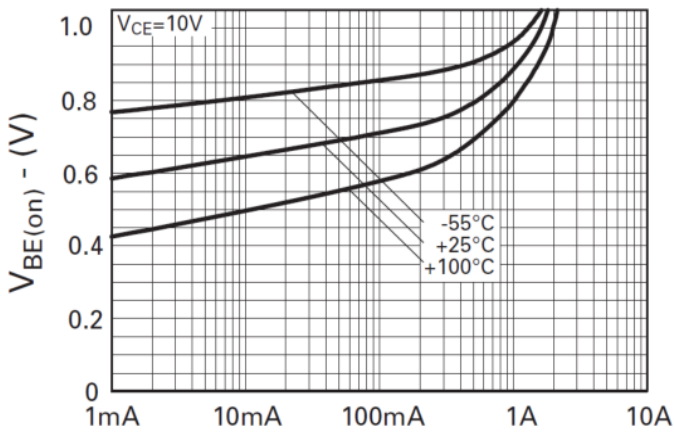

I_C - Collector current
 $V_{BE(on)}$ vs. I_C

Package Outline Dimensions

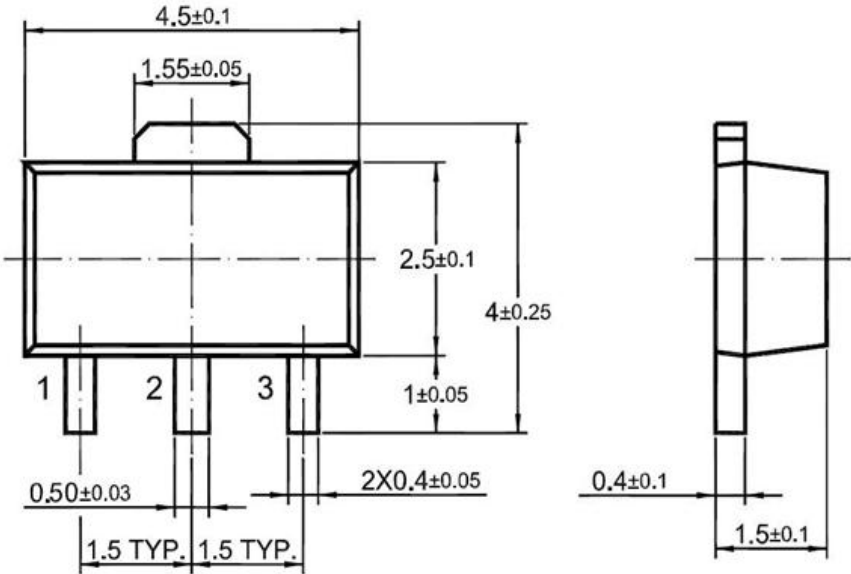

Package	Packaging code	Reel Size	Quantity	Box	Carton
SOT-89	-T	7 inch	1000 pcs	12000pcs	48000pcs

DISCLAIMER NOTICE

Rectron Inc reserves the right to make changes without notice to any product specification herein, to make corrections, modifications, enhancements or other changes. Rectron Inc or anyone on its behalf assumes no responsibility or liability for any errors or inaccuracies. Data sheet specifications and its information contained are intended to provide a product description only. "Typical" parameters which may be included on RECTRON data sheets and/ or specifications can and do vary in different applications and actual performance may vary over time. Rectron Inc does not assume any liability arising out of the application or use of any product or circuit.

Rectron products are not designed, intended or authorized for use in medical, life-saving implant or other applications intended for life-sustaining or other related applications where a failure or malfunction of component or circuitry may directly or indirectly cause injury or threaten a life without expressed written approval of Rectron Inc. Customers using or selling Rectron components for use in such applications do so at their own risk and shall agree to fully indemnify Rectron Inc and its subsidiaries harmless against all claims, damages and expenditures.