

**Surface Mount Silicon Zener Diodes Zener
Voltage 3.3 ~ 260 V , 5.0 Watt Power Dissipation**

FEATURES

- * Glass passivated chip
- * Low inductance
- * Built-in strain relief
- * High peak reverse power dissipation
- * Low reverse leakage
- * For use in stabilizing and clipping with high power rating
- * P/N suffix V means AEC-Q101 qualified, e.g:SMB5333BV
- * P/N suffix V means Halogen-free

FEATURES

- * Case: DO-214AA Molded plastic
- * Polarity: Color band denotes cathode end
- * Mounting position: Any

MAXIMUM RATINGS AND ELECTRICAL CHARACTERISTICS

Ratings at 25 °C ambient temperature unless otherwise specified.



DO-214AA

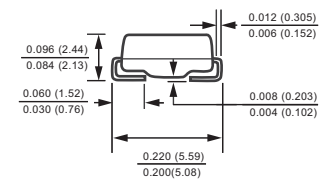
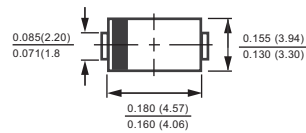

Unit: inch(mm)

MAXIMUM RATINGS (At T_A = 25°C unless otherwise noted)

PARAMETER	SYMBOL	VALUE	UNITS
DC Power dissipation at T _L = 75 °C(Note 1)	P _D	5.0	W
Typical Thermal Resistance (Note 2)	R _{θJL}	15	°C/W
Typical Thermal Resistance (Note3)	R _{θJA}	90	°C/W
Maximum surge current	I _{zsm}	11.5	A
Maximum forward voltage at I _f =200mA	V _F	1.2	Volts
Operating and Storage Temperature Range	T _J , T _{STG}	-55 to + 150	°C

- NOTES : 1. T_L=Lead temperature at 3/8" (9.5mm)from body
 2.Suggested solder pad layout: PAD Length 1.7mm
 3.Suggested solder pad layout : PAD Width 2.15mm

2026-06/61
REV:F

RATING AND CHARACTERISTICS CURVES (SMB5333B THRU SMB5389B)

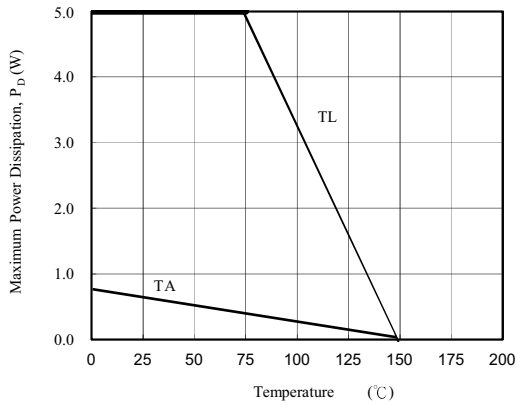

Fig. 1 - Power Temperature Derating Curve

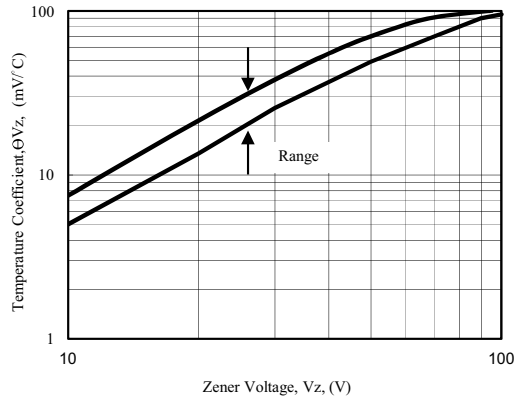

Fig. 2 - Temperature Coefficients v.s. Zener Voltage

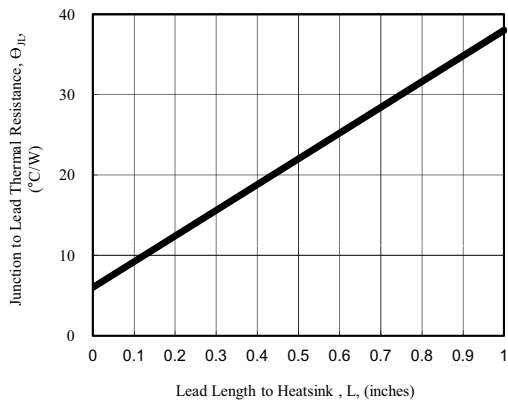

Fig. 3 - Typical Thermal Resistance v.s. Lead Length

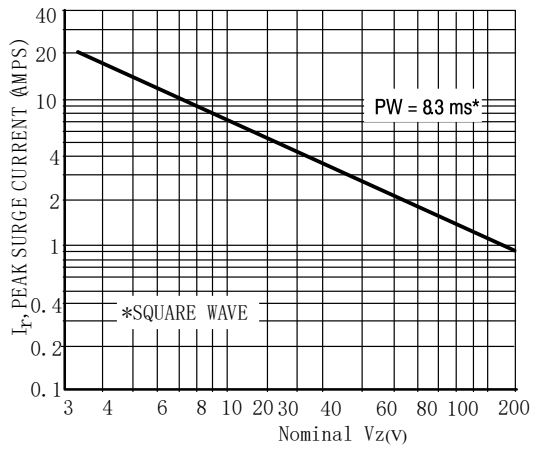

Figure 4. Maximum Non-Repetitive Surge Current versus Nominal Zener Voltage

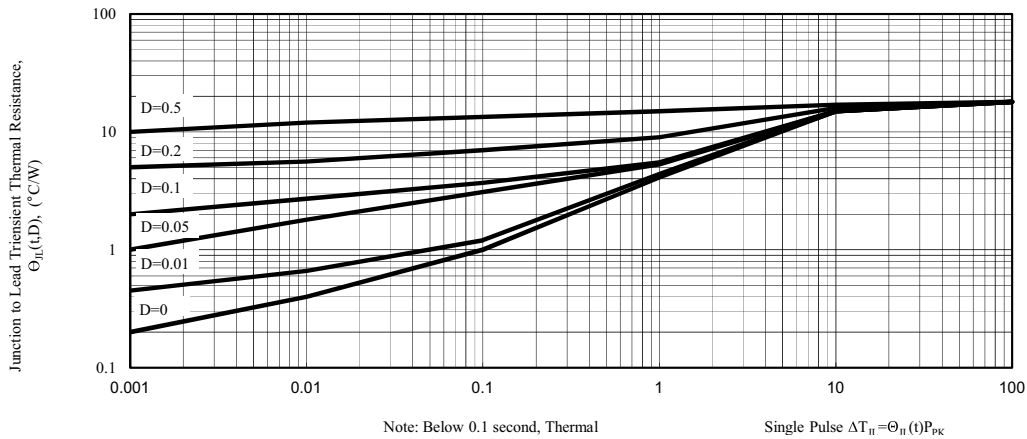
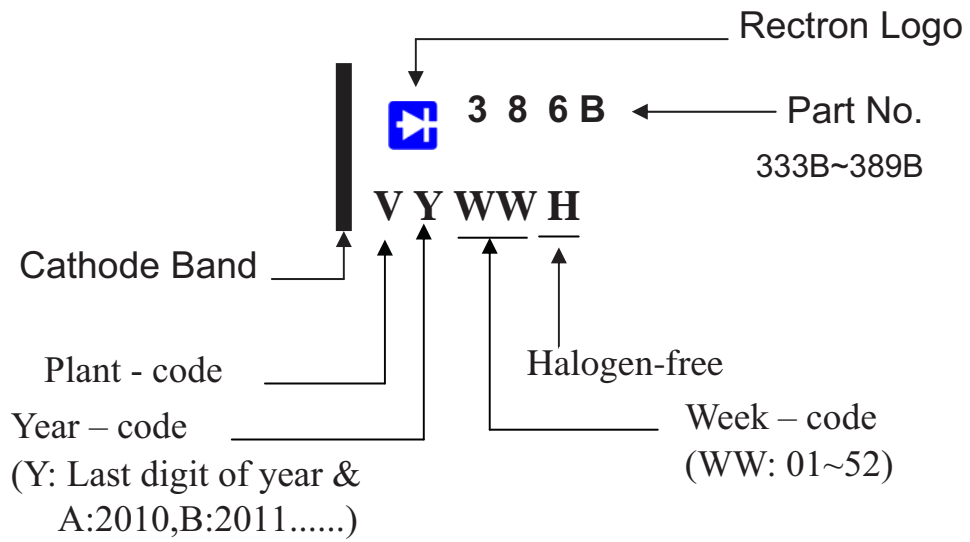

Fig. 5 - Typical Thermal Response L, Lead Length=3/8inch

Part Number	Device Marking Code	Nominal Zener Voltage @I _T			I _{ZT} (mA)	Maximum Zener Impedance			Maximum Reverse Leakage Current		Maximum DC Zener Current
		V _{Z AVE} (V)	V _{Z MIN} (V)	V _{Z MAX} (V)		Z _{ZT MAX} (Ω) @I _{ZT}	Z _{ZK MAX} (Ω) @I _{ZK}	I _{ZK} (mA)	I _R (uA) @V _R	V _R (V)	
SMB5333B	333B	3.3	3.14	3.47	380.0	3.0	400	1.00	300	1.0	1437.0
SMB5334B	334B	3.6	3.42	3.78	350.0	2.5	500	1.00	150	1.0	1317.0
SMB5335B	335B	3.9	3.71	4.10	320.0	2.0	500	1.00	50	1.0	1216.0
SMB5336B	336B	4.3	4.09	4.52	290.0	2.0	500	1.00	10	1.0	1103.0
SMB5337B	337B	4.7	4.47	4.94	260.0	2.0	450	1.00	5	1.0	1009.0
SMB5338B	338B	5.1	4.85	5.36	240.0	1.5	400	1.00	1.0	1.0	930.0
SMB5339B	339B	5.6	5.32	5.88	220.0	1.0	400	1.00	1.0	2.0	846.0
SMB5340B	340B	6.0	5.70	6.30	200.0	1.0	300	1.00	1.0	3.0	790.0
SMB5341B	341B	6.2	5.89	6.51	200.0	1.0	200	1.00	1.0	3.0	765.0
SMB5342B	342B	6.8	6.46	7.14	175.0	1.0	200	1.00	10.0	5.2	700.0
SMB5343B	343B	7.5	7.13	7.88	175.0	1.5	200	1.00	10.0	5.7	630.0
SMB5344B	344B	8.2	7.79	8.61	150.0	1.5	200	1.00	10.0	6.2	580.0
SMB5345B	345B	8.7	8.27	9.14	150.0	2.0	200	1.00	10.0	6.6	545.0
SMB5346B	346B	9.1	8.65	9.56	150.0	2.0	150	1.00	7.5	6.9	520.0
SMB5347B	347B	10.0	9.50	10.50	125.0	2.0	125	1.00	5	7.6	475.0
SMB5348B	348B	11.0	10.45	11.55	125.0	2.5	125	1.00	5	8.4	430.0
SMB5349B	349B	12.0	11.40	12.60	100.0	2.5	125	1.00	2	9.1	395.0
SMB5350B	350B	13.0	12.35	13.65	100.0	2.5	100	1.00	1	9.9	365.0
SMB5351B	351B	14.0	13.30	14.70	100.0	2.5	75	1.00	1	10.6	340.0
SMB5352B	352B	15.0	14.25	15.75	75.0	2.5	75	1.00	1	11.5	315.0
SMB5353B	353B	16.0	15.20	16.80	75.0	2.5	75	1.00	1	12.2	295.0
SMB5354B	354B	17.0	16.15	17.85	70.0	2.5	75	1.00	0.5	12.9	280.0
SMB5355B	355B	18.0	17.10	18.90	65.0	2.5	75	1.00	0.5	13.7	265.0
SMB5356B	356B	19.0	18.05	19.95	65.0	3.0	75	1.00	0.5	14.4	250.0
SMB5357B	357B	20.0	19.00	21.00	65.0	3.0	75	1.00	0.5	15.2	237.0
SMB5358B	358B	22.0	20.90	23.10	50.0	3.5	75	1.00	0.5	16.7	216.0
SMB5359B	359B	24.0	22.80	25.20	50.0	3.5	100	1.00	0.5	18.2	198.0
SMB5360B	360B	25.0	23.75	26.25	50.0	4.0	110	1.00	0.5	19.0	190.0
SMB5361B	361B	27.0	25.65	28.35	50.0	5.0	120	1.00	0.5	20.6	176.0
SMB5362B	362B	28.0	26.60	29.40	50.0	6.0	130	1.00	0.5	21.2	170.0
SMB5363B	363B	30.0	28.50	31.50	40.0	8.0	140	1.00	0.5	22.8	158.0
SMB5364B	364B	33.0	31.35	34.65	40.0	10.0	150	1.00	0.5	25.1	144.0
SMB5365B	365B	36.0	34.20	37.80	30.0	11.0	160	1.00	0.5	27.4	132.0
SMB5366B	366B	39.0	37.05	40.95	30.0	14.0	170	1.00	0.5	29.7	122.0
SMB5367B	367B	43.0	40.85	45.15	30.0	20.0	190	1.00	0.5	32.7	110.0
SMB5368B	368B	47.0	44.65	49.35	25.0	25.0	210	1.00	0.5	35.8	100.0
SMB5369B	369B	51.0	48.45	53.55	25.0	27.0	230	1.00	0.5	38.8	93.0
SMB5370B	370B	56.0	53.20	58.80	20.0	35.0	280	1.00	0.5	42.6	86.0
SMB5371B	371B	60.0	57.00	63.00	20.0	40.0	350	1.00	0.5	42.5	79.0
SMB5372B	372B	62.0	58.90	65.10	20.0	42.0	400	1.00	0.5	47.1	76.0
SMB5373B	373B	68.0	64.60	71.40	20.0	44.0	500	1.00	0.5	51.7	70.0
SMB5374B	374B	75.0	71.25	78.75	20.0	45.0	620	1.00	0.5	56.0	63.0
SMB5375B	375B	82.0	77.90	86.10	15.0	65.0	720	1.00	0.5	62.2	58.0
SMB5376B	376B	87.0	82.65	91.35	15.0	75.0	760	1.00	0.5	66.0	54.5
SMB5377B	377B	91.0	86.45	95.55	15.0	75.0	760	1.00	0.5	69.2	52.5
SMB5378B	378B	100.0	95.00	105.00	12.0	90.0	800	1.00	0.5	76.0	47.5
SMB5379B	379B	110.0	104.50	115.50	12.0	125.0	1000	1.00	0.5	83.6	43.0
SMB5380B	380B	120.0	114.00	126.00	10.0	170.0	1150	1.00	0.5	91.2	39.5
SMB5381B	381B	130.0	123.50	136.50	10.0	190.0	1250	1.00	0.5	98.8	36.6
SMB5382B	382B	140.0	133.00	147.00	8.0	230.0	1500	1.00	0.5	106.0	34.0
SMB5383B	383B	150.0	142.50	157.50	8.0	330.0	1500	1.00	0.5	114.0	31.6
SMB5384B	384B	160.0	152.00	168.00	8.0	350.0	1650	1.00	0.5	122.0	29.4
SMB5385B	385B	170.0	161.50	178.50	8.0	380.0	1750	1.00	0.5	129.0	28.0
SMB5386B	386B	180.0	171.00	189.00	5.0	430.0	1750	1.00	0.5	137.0	26.4
SMB5387B	387B	190.0	180.50	199.50	5.0	450.0	1850	1.00	0.5	144.0	25.0
SMB5388B	388B	200.0	190.00	210.00	5.0	480.0	1850	1.00	0.5	152.0	23.6
SMB5389B	389B	260.0	247.00	273.00	5.0	700.0	2500	1.00	0.5	210.0	15.3

Notes: The type number listed have a standard tolerance on the nominal zener voltage of ± 5%.

Marking Description



Mounting Pad Layout

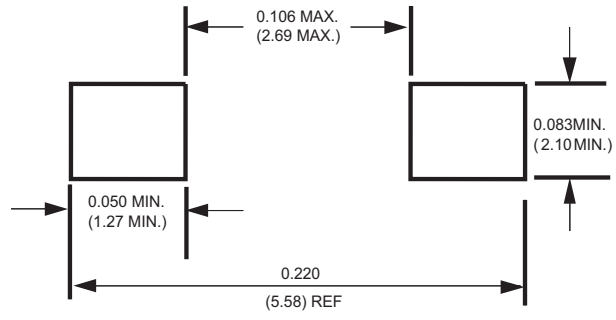

Dimensions in inches and (millimeters)

PACKAGING OF DIODE AND BRIDGE RECTIFIERS

REEL PACK

PACKAGE	PACKING CODE	EA PER REEL	EA PER INNER BOX	COMPONENT SPACE (mm)	TAPE SPACE (mm)	REEL DIA (mm)	CARTON SIZE (mm)	EA PER CARTON	GROSS WEIGHT(Kg)
SMB	-W	3,000	6,000	---	---	330	360*355*360	48,000	12.08

DISCLAIMER NOTICE

Rectron Inc reserves the right to make changes without notice to any product specification herein, to make corrections, modifications, enhancements or other changes. Rectron Inc or anyone on its behalf assumes no responsibility or liability for any errors or inaccuracies. Data sheet specifications and its information contained are intended to provide a product description only. "Typical" parameters which may be included on RECTRON data sheets and/ or specifications can and do vary in different applications and actual performance may vary over time. Rectron Inc does not assume any liability arising out of the application or use of any product or circuit.

Rectron products are not designed, intended or authorized for use in medical, life-saving implant or other applications intended for life-sustaining or other related applications where a failure or malfunction of component or circuitry may directly or indirectly cause injury or threaten a life without expressed written approval of Rectron Inc. Customers using or selling Rectron components for use in such applications do so at their own risk and shall agree to fully indemnify Rectron Inc and its subsidiaries harmless against all claims, damages and expenditures.